

GENERAL INSTALLATION INSTRUCTIONS  
SPAT + VALANCE SUPRA

Pos.	Qty	Part	
1	1 x		Mudguard 140x4000 VALANCE (example)
2	1 x		SPAT
3	1 x		SPAT Supra
4	2 x		Plastic rivet M6
5	2 x		Washer M6x18

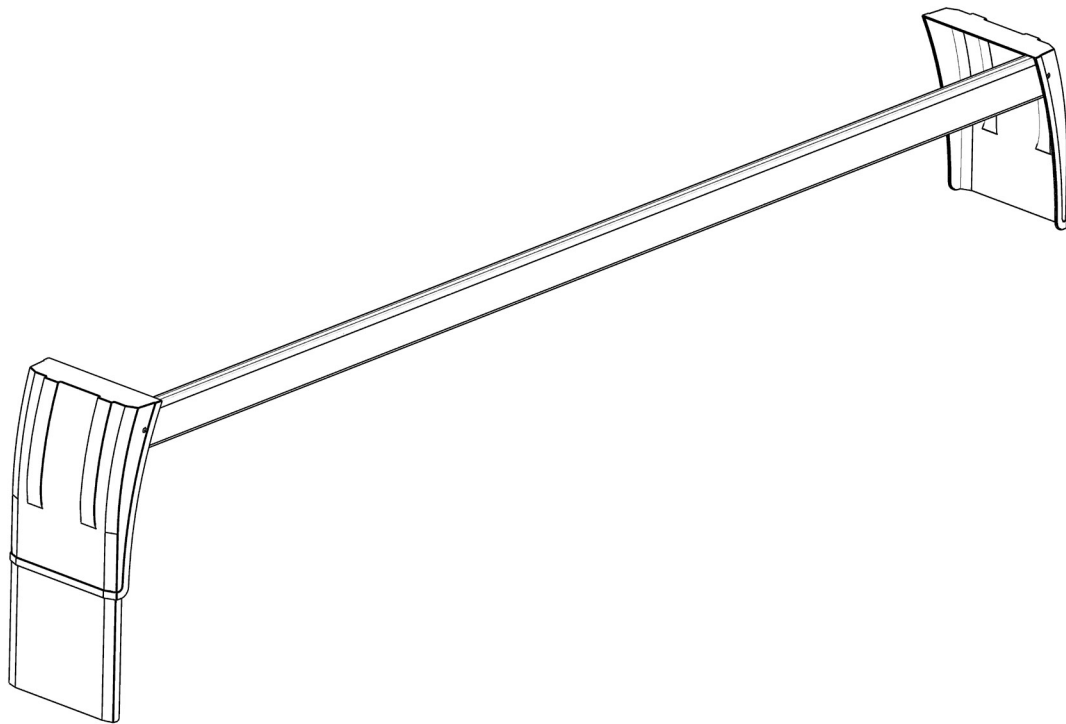

Drill 6x20 mm holes at both ends.

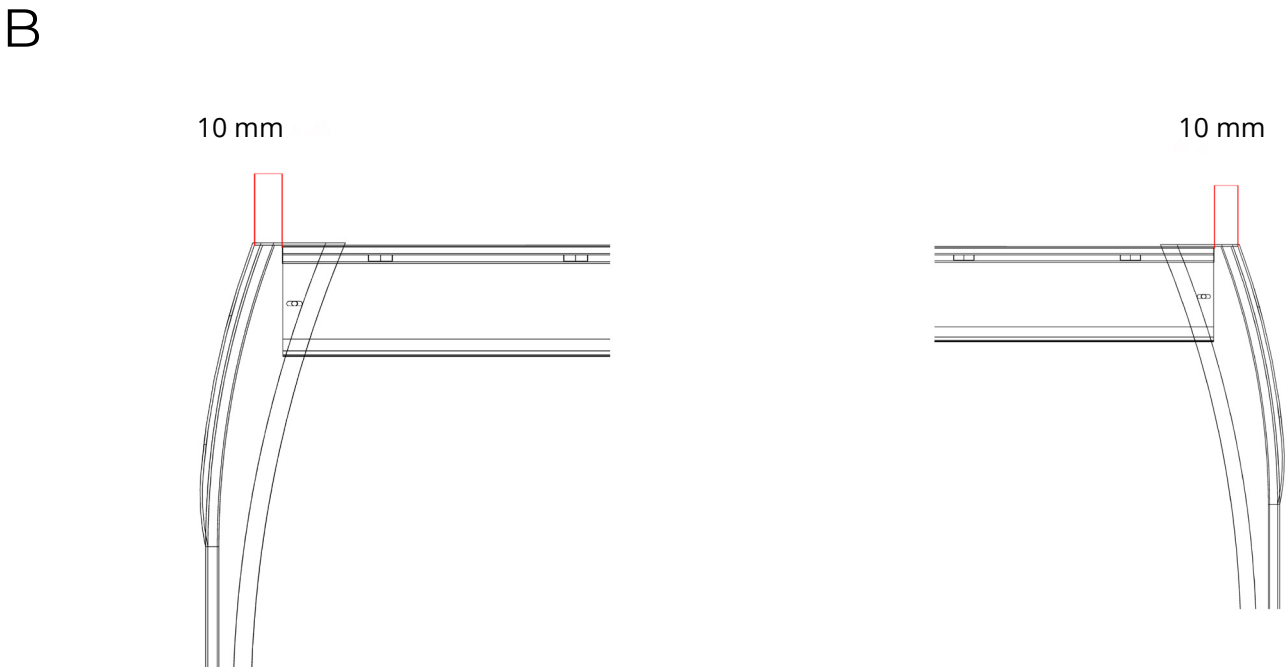

Recommended distance between AL-PROFILE and SPAT inner corner = 10 mm



Drill a 6 mm hole on both SPAT mudguards (2), (3) and attach the VALANCE between the mudguards.

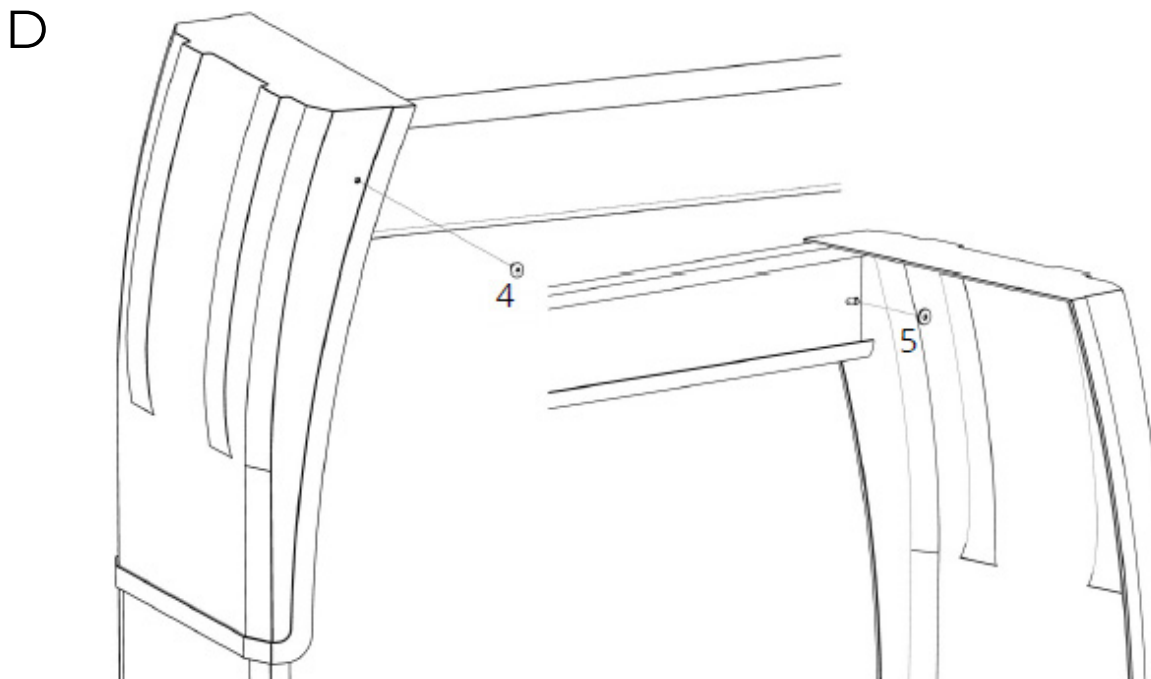

Insert the plastic rivet (4) from the outside through the washer (5) on the inside of the VALANCE mudguard.

E

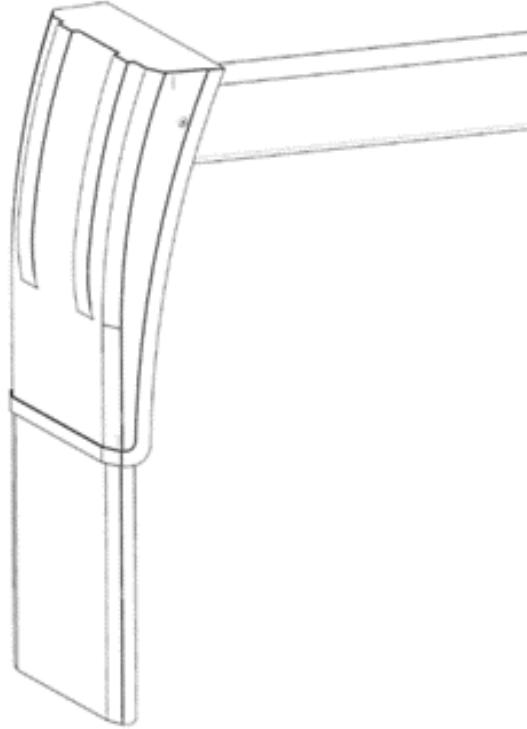

Done. This solution allows the movement caused by thermal expansion.